

11 EXTERIOR DOOR SILL
N.T.S.

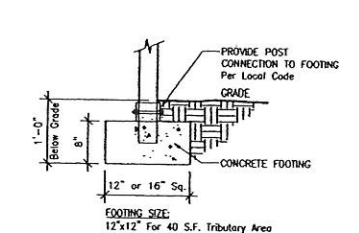

10 DECK FOOTING SECTION
3/4" = 1'-0"

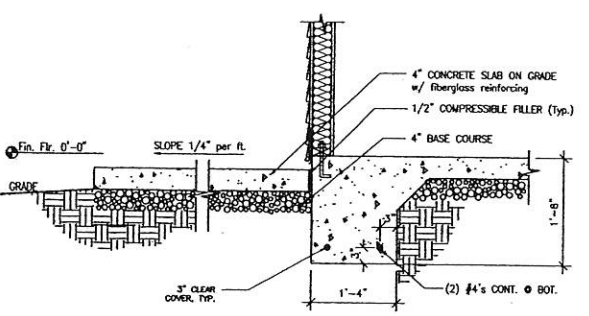

09 WALL SECTION @ Rear w/ Patio
3/4" = 1'-0"

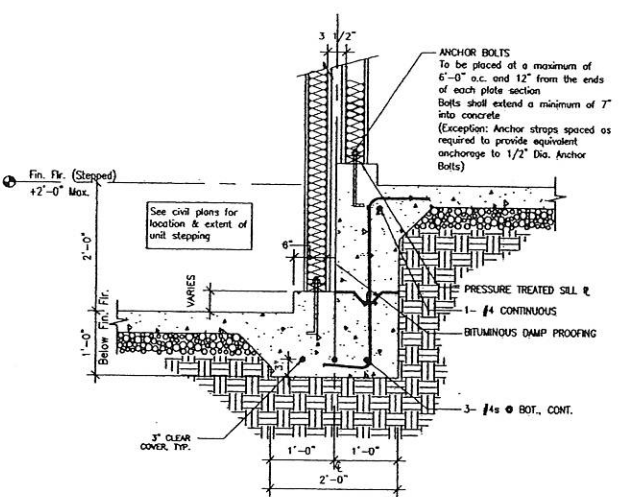

08 GARAGES @ Stepped Separation Walls
3/4" = 1'-0"

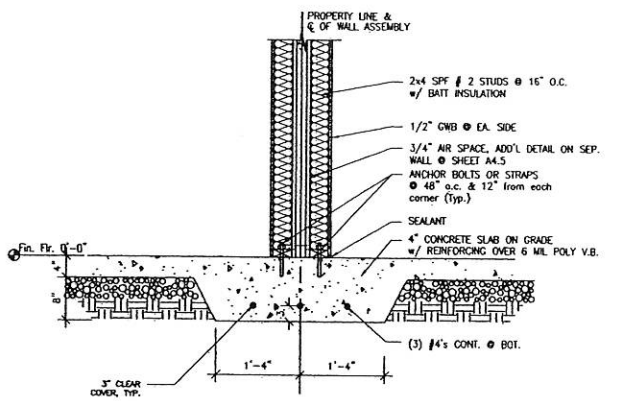

07 THRESHOLD SLAB @ Unit Separation Walls
3/4" = 1'-0"

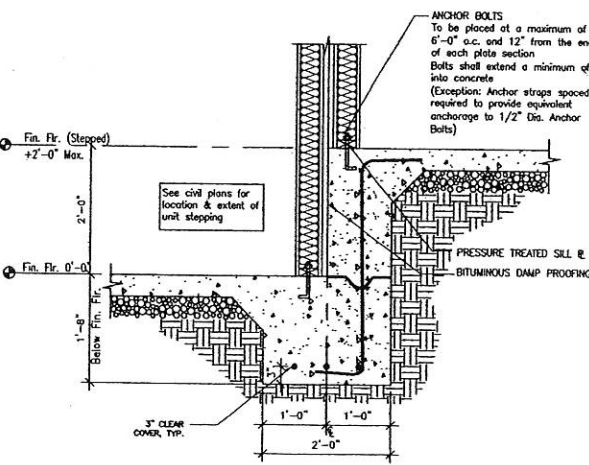

06 FOUNDATION @ Stepped Separation Walls
3/4" = 1'-0"

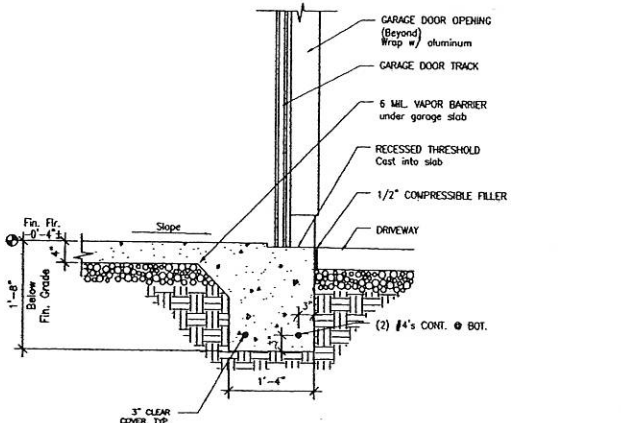

05 WALL SECTION @ Garage Opening
3/4" = 1'-0"

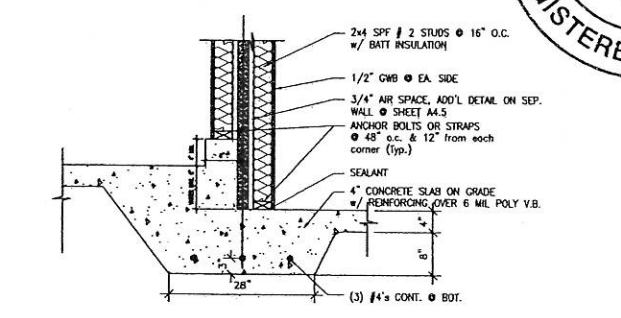

04 SEPARATION WALL FOOTING @ Garage
3/4" = 1'-0"

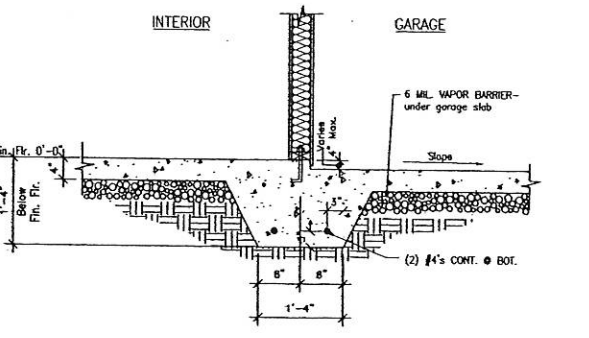

03 WALL SECTION @ Garage Perimeter
3/4" = 1'-0"

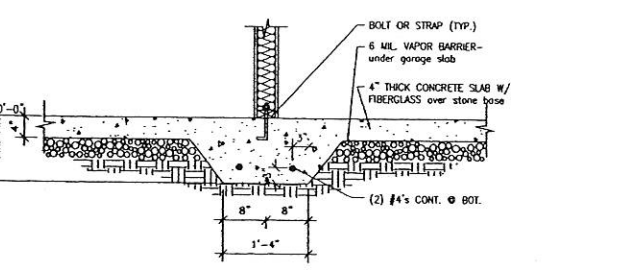

02 THRESHOLD SLAB @ Interior Bearing Walls
3/4" = 1'-0"

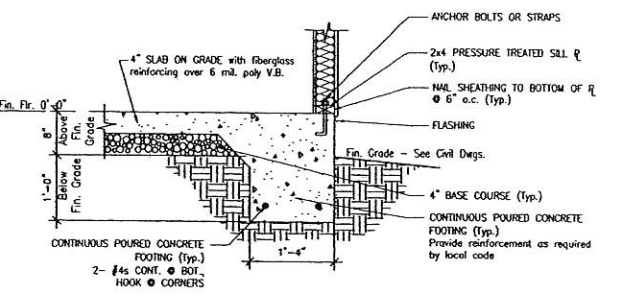

01 WALL SECTION @ Exterior
3/4" = 1'-0"

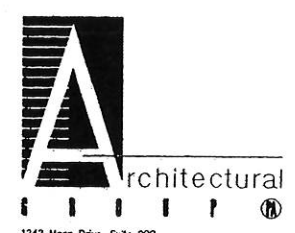

1242 Mann Drive, Suite 200
Matthews, North Carolina 28105
www.urbanarchitecturalgroup.com
P: 704.841.1899 F: 704.841.8440
These drawings are an instrument of service provided by Urban Architectural Group, PA.
© 2006 URBAN ARCHITECTURAL GROUP P.A.
All rights reserved. Unauthorized Reproduction Prohibited.

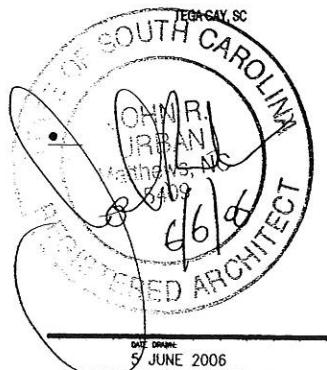

DATE: 9 JUNE 2006
PROJECT NO.: 2530
ISSUED FOR: PERMIT & CONSTRUCTION
5 JUNE 2006

AF1.2