



1242 Mann Drive, Suite 200  
 Matthews North Carolina 28105  
 www.urbanarchitecturalgroup.com  
 P: 704.841.1899 F: 704.841.8440

These drawings are an instrument of service provided by Urban Architectural Group, PA.

© 2006 URBAN ARCHITECTURAL GROUP P.A.  
 All rights reserved. Unauthorized Reproduction Prohibited.



LAKE SHORE TOWN HOMES  
 TEGA CAY, SC

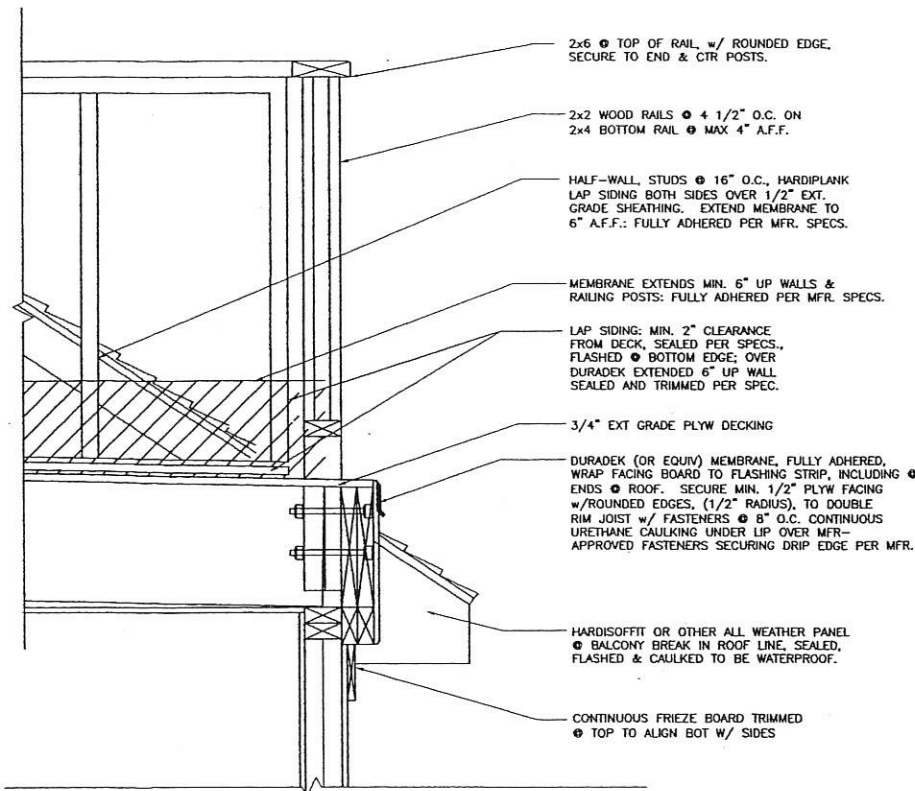

05 DETAIL - Scupper @ Balcony - Unit A  
 1 1/2" = 1'-0"

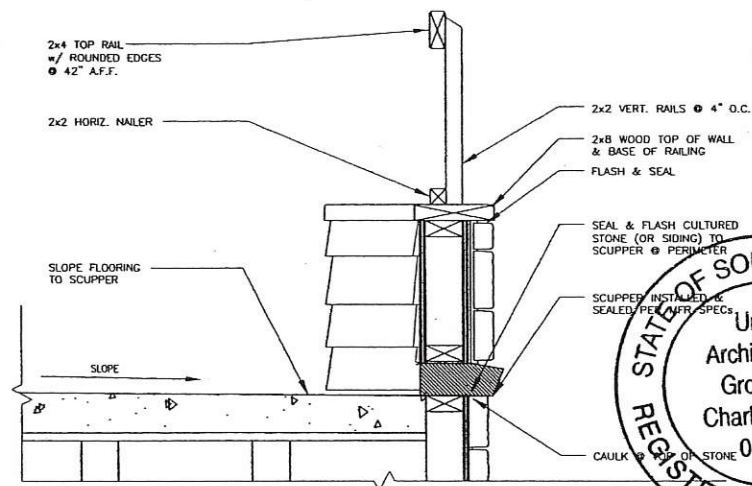

04 DETAIL - Balcony Guardrail @ Unit A  
 1 1/2" = 1'-0"

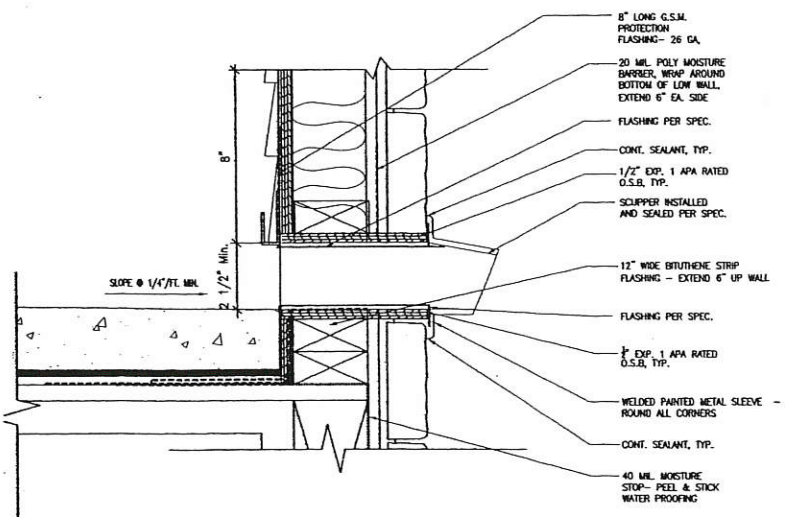

03 DETAIL - Scupper @ Balcony - Unit A

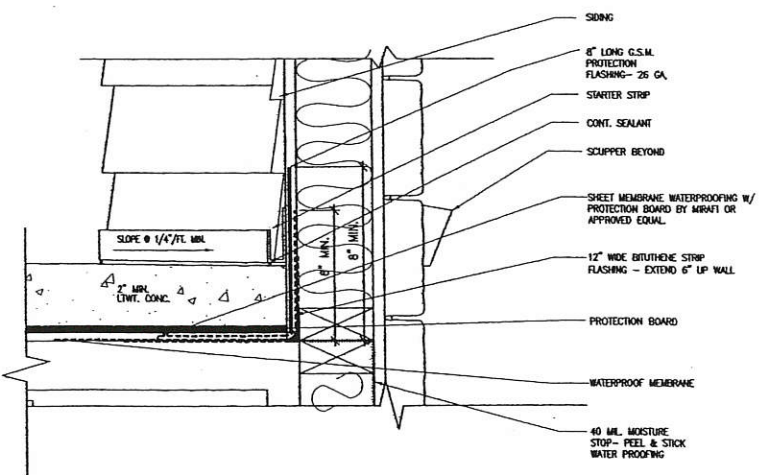

02 DETAIL - Balcony Edge @ Unit A

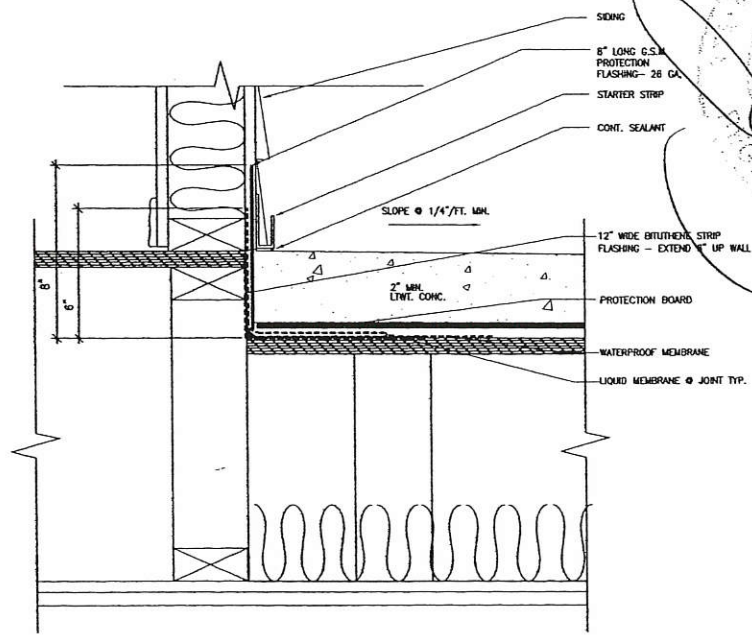

01 DETAIL - Balcony @ Unit A



BALCONY DETAILS

|              |                       |
|--------------|-----------------------|
| DATE DRAWN:  | 5 JUNE 2006           |
| PROJECT NO.: | 2530                  |
| ISSUED FOR:  | PERMIT & CONSTRUCTION |
| DATE:        | 5 JUNE 2006           |

A5.4